



Piper Aircraft, Inc.
 2926 Piper Drive
 Vero Beach, FL, U.S.A. 32960

SERVICE NO. 1345A BULLETIN

PIPER CONSIDERS COMPLIANCE MANDATORY

Date: September 17, 2021

(S)

Service Bulletin (SB) 1345A supersedes SB 1345, except for requirements of SB 1345 that are mandated by an FAA-issued Airworthiness Directive.

Aircraft wing spars that passed inspection in compliance with SB 1345 are in compliance with SB 1345A.

Aircraft wing spars that failed a previous inspection in compliance with SB 1345 must be made compliant with Instructions in SB 1345A, whether installed on an aircraft or intended for scrap.

SUBJECT:

MAIN WING SPAR INSPECTION

REASON FOR REVISION:

SB 1345A improves the inspection procedures and expands the feedback form.

MODELS AFFECTED:

- PA-28R-180 Arrow

- PA-28R-200 Arrow

- PA-28R-200 Arrow II
- PA-28R-201 Arrow III

- PA-28R-201T Turbo Arrow III

- PA-28RT-201 Arrow IV
- PA-28RT-201T Turbo Arrow IV

SERIAL NUMBERS AFFECTED:

- 28R-30002 through 28R-31270;
- 28R-7130001 through 28R-7130013
- 28R-35001 through 28R-35820;
- 28R-7135001 through 28R-7135229
- 28R-7235001 through 28R-7635545
- 28R-7737002 through 28R-7837317;
- 2837001 through 2837061; 2844001 and up
- 28R-7703001 through 28R-7803374;
- 2803001 through 2803012
- 28R-7918001 through 28R-8218026
- 28R-7931001 through 28R-8631005;
- 2831001 through 2831038

COMPLIANCE TIME:

Upon reaching 5,000 hours time in service (TIS), compliance is to coincide with the next regularly scheduled maintenance event, but not to exceed the next 100 hours TIS.

NOTE: SB 1345 (original release) provided the option to extend the compliance time no more than one calendar year from its March 27, 2020, publication date, which has expired. No compliance time extension is being offered for SB 1345A.

NOTE: Any wing spar that failed a previous inspection in compliance with SB 1345, but has not been replaced (i.e., the aircraft has not been in operation since), must be reinspected with Instructions in SB 1345A.

APPROVAL: The engineering aspects of the eddy current inspection method (on pages 2 and 3 of this document) have been shown to comply with the applicable Federal Aviation Regulations and are FAA approved.

PURPOSE: This service bulletin mandates a one-time inspection of the affected aircraft for cracks at specific bolt hole locations in the main wing spars, followed by reporting the findings to Piper, regardless of the results.

If compliance with SB 1345 (original) was accomplished and crack indications were found, the inspections in SB 1345A are to be accomplished on a wing spar even if the intent (upon compliance with SB 1345) was to scrap it. The data collected will be essential in determining service actions applicable to all of the affected aircraft, such as the repairability of some wing spars.

INSPECTION METHODS: Follow the Instructions for the implementation of the inspection methods described here. This section describes the methodology for eddy current and fluorescent penetrant inspections.

**Eddy Current
Inspection Method**

The standard, SAE ARP4402, "Eddy Current Inspection of Open Fastener Holes in Aluminum Aircraft Structure," should be used when performing the applicable inspections under Instructions, below.

NOTE: Prior to inspection, wipe the surfaces clean using a soft cloth dampened with isopropyl alcohol or mineral spirits.

Personnel Qualifications:

Personnel that perform eddy current and/or fluorescent penetrant inspections shall be qualified in accordance with NAS 410 (or equivalent standards that are listed in FAA Advisory Circular (AC) 65-31B) as qualified Level II or Level III nondestructive inspection personnel.

Eddy current bolt hole inspections shall be performed in accordance with SAE ARP4402 or a written procedure specific to the aircraft being inspected and approved by the FAA.

Equipment:

- Equipment used shall provide impedance plane diagrams.
- Probes may be either absolute or differential coil configurations.
- For manual bolt hole probing: use probe collars at an increment of every 1/64 inch to ensure the uniform depth of rotation and to aid in reducing lift-off effects.
- Automated scanning systems may be used.
- Bolt hole probes shall match as closely as possible, but not exceed, the bolt hole diameter. Split core probes may be expanded to a maximum of 0.050 inch beyond the probe's nominal diameter (based on the probe manufacturer's recommendation). The fill factor shall be 80 percent minimum.
- Holes being inspected shall be no larger than 10 percent of the expanded bolt hole diameter.
- A right angle (90-degree) surface probe may be used for further detail indication, if needed.

Reference Standard:

- Any reference standard used shall be of the same conductivity 2024-T3 within ± 15 percent IACs. It shall have electrical discharge machining (EDM) notches for simulating defects as calibration references.
- The surface finish shall be 63 RHR or better.
- The reference standard shall have a corner notch size of 0.030 x 0.030 inch (screen set at minimum of three divisions vertical with a phase signal of between 45 and 120 degrees separation from the horizontal lift-off).
- Frequency used shall be between 100 and 500 kHz.
- The calibration shall be checked at the beginning and end and every 30 minutes of inspections.

Equipment Guidelines:

The following is a list of equipment capable of performing the inspections described in this service bulletin. The following optional inspection equipment has been shown to be adequate to conduct this procedure and is provided as an example only. Other equipment meeting the requirements under the heading "Equipment" may be used.

NOTE: Other manufacturers offer equivalents to what is listed here (including GE, Hocking, Rohman, Uniwest, VM, and Zetec).

- NORTEC 500D or 600D Series Portable Eddy Current Flaw Detector – Olympus
- Bolt hole probe, 0.375 in. with 0.062 inch shielded coil – Olympus
- A bolt hole probe must first be used to inspect the bolt holes; an Olympus right angle (90-degree) surface probe with 0.062 inch shielded coil may be used for a more detailed inspection, if needed.
- For the calibration standard (NIST traceable) for bolt holes and surface, use the Air Force General Purpose Eddy Current Standard with the following criteria:
 - Bolt hole: 0.030 x 0.030 inch corner notch, 0.030 inch radial notch
 - Surface: 2024-T3: 0.008, 0.020, and 0.040 inch depth EDM notches
 - Frequency 300-500 kHz, EDM notch set at five (5) divisions screen height

Acceptance:

Using the successive evaluation procedure provided under Instructions, Step 3, relevant crack or crack-like indications with amplitudes equal to or greater than 50 percent of the reference level signal shall be rejected and documented (i.e., such an amplitude reading may mean that the spar does not meet type design requirements and must be reported to Piper Aircraft for disposition; fluorescent penetrant inspection is to be accomplished on relevant indications as part of the evaluation).

The subject bolt holes, as viewed from beneath the wing, penetrate the aluminum sheets in the lower skin lap joint, the lower surface of the wing spar box, the lower flanges of the spar extrusions, and the web doublers on the upper surface of the lower spar flange. The pass-fail criteria of this inspection is only applicable to a crack in the spar extrusion. Damage in the other areas mentioned should be reported to Piper Aircraft for disposition.

It is possible for non-crack damage, such as fay gaps, thread marks, gouges, or edge chips in the spar bolt hole to return a flaw indication similar to that of a crack. Multiple indications or broad indications may be associated with fay gaps or swarf within these fay gaps and may not be representative of cracks.

If an indication is observed, the hole should be carefully inspected for non-crack damage to eliminate the possibility of a false crack indication. Any non-crack damage, including elongated holes, should be reported to Piper for disposition. (See contact information below.)

Fluorescent Penetrant Inspection Method

If there is paint in the inspection area, remove it from the area specified using only chemical processes. Abrasives or other mechanical methods for paint removal will hide the existence of any cracks, making it impossible to do an accurate inspection. Use isopropyl alcohol to wipe clean the areas to be inspected where paint was removed.

Perform a fluorescent penetrant inspection for cracks as described in FAA AC 43.13-1B, "Acceptable Methods, Techniques, and Practices – Aircraft Inspection and Repair," Chapter 5, Section 5.

If no cracks are detected during the inspection, wipe the area of inspection clean with isopropyl alcohol. Apply primer to the areas where paint was removed for inspection using MIL-PRF-85582 Type I Class C2 primer. Alternatively, use any primer conforming to MIL-PRF-23377 and apply per the primer manufacturer's instructions.

Any non-crack damage, including elongated holes, should be reported to Piper for disposition. (See contact information below.)

To Contact Piper:

Any non-crack damage that is discovered as a result of inspections should be reported to Piper Aircraft, at CustomerService@piper.com or (+1) 772-299-2141. Piper's normal business hours are Monday through Friday, 7:30 a.m. to 4:30 p.m. (Eastern).

INSPECTION AREA CARE:**Care for Bolts and Bolt Holes**

To ease bolt removal and avoid damage to the bolt holes, follow this guidance.

- Apply penetrating oil around all washers in the inspection area. Capillary action will draw the oil to the bolt shank to facilitate removal. One such oil is Kroil Penetrating Oil Aerosol, from Kano Laboratories (visit www.kroil.com and see "Where To Buy").
- Within the instructions for wing removal found in the applicable Piper AMM, there is the statement, "Arrange and put in place a suitable fuselage cradle and supports for both wings." Proper placement of these supports can neutralize the shear loading of the bolt at the interface of the wing spar and spar box, easing bolt removal.
- Remove the nut and washers. After removing the nut, apply torque to the bolt head to rotate the bolt approximately one turn, to help draw in the penetrating oil and break the bolt shank free from the hole. Do not wrench the bolt out of its hole, because this can result in thread marking of the hole.
- Before removing a bolt from its hole, thoroughly clean all debris from the exposed threaded end. Use a nylon bristle brush, as necessary, to remove all debris from the threads and solvent clean using acetone.
- Ideally, three people should work simultaneously to remove the bolts. This approach should not demand a lot of effort from the group, as follows:
 - One person adjusts the wing supports or deflects the wing tip up and/or down to neutralize the shear loading.
 - A second person underneath the aircraft pushes the threaded end of the bolt to move it up and out of the hole.
 - A third person, in the aircraft, would receive and remove the pushed bolt.

- For the person underneath the aircraft: a suitable non-marring tool (such as a 1/4-inch wooden dowel) may be used to push the bolt completely upwards through the hole. If necessary, use a rubber mallet or equivalent to very gently tap the lower end of the tool upwards – do not to make contact with the hole bore.
- Clean the inspection areas using acetone.

Cleaning Surface Imperfections:

Surface imperfections (blemishes, drag marks or scratches) in the hole bore can be cleaned – deburred, smoothed, and polished – using a medium (brown colored) or fine (rust colored) rubberized abrasive, either a point or cylinder, on a 1/16-inch mandrel in a rotary tool:

- Cratex Q8M or Q8F – 1 x 9/32 bullet point
- Cratex Q6M or Q6F – 7/8 x 1/4 cylinder

The best results are obtained between 7,500 and 15,000 RPM, using light work pressure. To procure Cratex points, call 800-800-4077 or visit www.cratex.com.

INSTRUCTIONS:

WARNING: FLIGHT WITH KNOWN CRACKS IN THE AIRCRAFT STRUCTURE IS NOT PERMITTED.

NOTES:

- The instructions contained within this service bulletin are applicable only to aircraft that conform to type design at the interface of the main wing spar and spar box. Any previously approved repairs or modifications may require alternate methods, instructions and hardware.
 - Temporary removal of interior components, fairings and/or access panels may be required in order to accomplish the instructions contained in this service bulletin.
 - Refer to the applicable Piper Airplane Maintenance Manual (AMM) for model specific details. Refer to the applicable Piper Airplane Parts Catalog (IPC) for the type and size of replacement hardware.
 - These instructions apply to both the left and right wings.
1. Locate the two (2) outermost main spar attach bolts, as shown in Figure 1, installed on the lower cap of the left and right main spar, on the forward and aft sides of the spar web.

CAUTION: DO NOT DRIVE OUT MAIN WING SPAR BOLTS. TAKE EXTREME CARE NOT TO DAMAGE BOLT HOLES.

CAUTION: DO NOT ROTATE BOLTS WHEN THE THREADS ARE INSIDE THE BOLT HOLE.

NOTE: Make a record of the type, number and orientation of washers in the hardware stack-up prior to bolt removal at each bolt location, to ensure proper reassembly upon completion of the inspection. Make special note of the condition and placement of washers which have a radiused outer diameter, Piper part numbers 96352-002 and 96352-003.

NOTE: When radius washers are properly installed, the radius feature of the washer will be oriented to match the radius of the adjacent structure, as shown in Figure 1, Detail D.

2. Carefully remove the two (2) wing spar attach bolts. Discard the bolts and nuts. Retain or replace the washers, depending on condition. Review “Care for Bolts and Bolt Holes,” above, prior to accomplishing this step.

3. Inspect the inner surface of each bolt hole in the lower wing spar cap. Figure 1 provides cross sections of the main wing spar, and identifies the bolt hole inspection areas.

NOTES:

- The inspection steps in these instructions are visualized in Figure 2, a process flowchart.
 - It is recommended that technicians prepare and/or enter their responses on the feedback form throughout the inspection process. (For legibility, fill out the form digitally, printing it only for signature purposes.)
 - Please provide evidential photographs in support of inspection results.
 - If a previous eddy current inspection (ECI) revealed an indication, then, at owner/operator discretion, the inspections described in this service bulletin may begin at Step 3. b, with wing removal (omitting the inspections with the wing installed).
- a. Perform the ECI method (with the wing installed), following the guidance under Inspection Methods, above.
- If no indications are present, then proceed to Step 4.
 - If an indication is found, proceed to Step b.
- b. If an indication still exists with the wing installed, then the wing shall be removed in accordance with the applicable Piper AMM and the guidance under “Care for Bolts and Bolt Holes,” above. Prior to removal, tag the wing to be removed with the aircraft serial number.
- NOTE: Flip the removed wing 180 degrees so that the lower wing surface is facing up, in order to gain optimum access to the bolt hole in the wing spar.
- c. Perform the fluorescent penetrant inspection (FPI) method on the subject holes with an eddy current indication. FPI improves situational awareness of the inspection area and potential contributors to false positives (e.g., fay gaps, swarf, etc.); it can further identify potential false positives and corroborate eddy current findings (additional ECIs are appropriate, as necessary). Follow the guidance under Inspection Methods, above.
- NOTE: If the technician accomplishing FPI is not the ECI technician, then the ECI technician shall observe the FPI to gain situational awareness of the inspection area for the benefit of the second ECI in Step g.
- NOTE: Performing FPI helps to classify persistent eddy current indications as being a crack or not a crack (other damage).
- d. Measure subject bolt hole diameters using a pin gauge.
- If diameter is within 0.377 – 0.379 in. range, proceed to Step e.
 - If diameter is outside of this range, proceed to Step h.
- e. Clean the subject bolt holes, as described under “Cleaning Surface Imperfections,” above.
- f. Measure subject bolt hole diameters using a pin gauge again.
- If diameter is within 0.377 – 0.379 in. range, proceed to Step g.
 - If diameter is outside of this range, proceed to Step h.
- g. Perform the ECI a second time on the subject holes with indications, following the guidance under Inspection Methods, above.
- If all indications are below 50 percent (as defined under the “Acceptance” section of “Eddy Current Inspection Method,” above) proceed to Step 4. However, it is recommended to perform an ECI on the spar box bolt hole that is associated with locations where indications were found while the wing was installed.
 - If any eddy current indication still exists that is equal to or greater than 50 percent, then proceed to Step h.

- h. Consult with a NAS 410 (or equivalent standard per FAA AC 65-31B) Level III technician to interpret the NDT results and provide final determination of indications. In all cases, regardless of any other actions, complete Step 4 – fill out the feedback form (and submit it to Piper Aircraft).
- If any indication is determined to be a crack, then the hole shall be rejected and documented (i.e., the spar does not meet type design requirements) and the wing shall be tagged as “Rejected per SB 1345A.” Complete Step 5.
 - If all eddy current indications are determined not to be cracks, but non-crack damage is found, see “To Contact Piper,” above. Do not go past Step 4 (without Piper approval).
4. Complete the inspection [feedback form \(link\)](#), regardless of the findings. (For legibility, fill out the form digitally, printing it only for signature purposes.)
- NOTE:** If a prior inspection took place, then acknowledge this in the area provided on the linked feedback form (revised for SB 1345A).
- If completion of the revised inspection procedures in SB 1345A finds no indications where an earlier inspection did find indications, then immediately report this change of outcome to Piper Aircraft.
- If any cracks are found, return the form to Piper within 24 hours (or one business day). Proceed to Step 5.
 - If no cracks nor other damage are found, return the form to Piper as soon as possible, but not to exceed 5 business days.
 - Proceed to Step 6 only if no other (that is, non-crack) damage is found.
 - If other damage is found, see “To Contact Piper,” above.
5. Prior to further flight, contact Piper Aircraft for disposition of any wing or wing spar with an indication. (Replacement wings or wing spars that are not new must also be shown to be free of cracks in accordance with the inspections in this service bulletin.)
- NOTE:** To report to Piper within 24 hours any cracks that have been discovered, contact Piper Customer Service at CustomerService@piper.com. Piper’s normal business hours are Monday through Friday, 7:30 a.m. to 4:30 p.m. (Eastern).
6. Reinstall the wing, if removed in Step 3, in accordance with the applicable AMM. Use caution while reinstalling the wing to avoid damage to aircraft structure; clean the subject bolt holes prior to installing bolts. Install new wing spar bolts and nuts per the applicable Piper IPC. Existing washers in good condition may be reused. Torque the nuts according to the applicable AMM.
- NOTE:** When radius washers are properly installed, the radius feature of the washer will be oriented to match the radius of the adjacent structure, as shown in Figure 1, Detail D.
7. Make a logbook entry documenting compliance with this service bulletin.

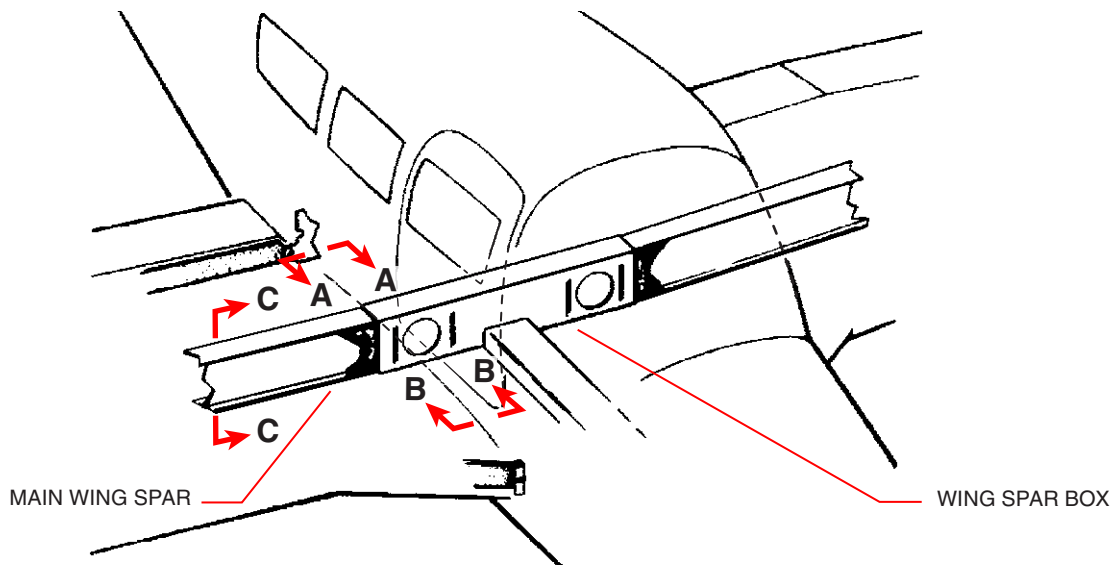
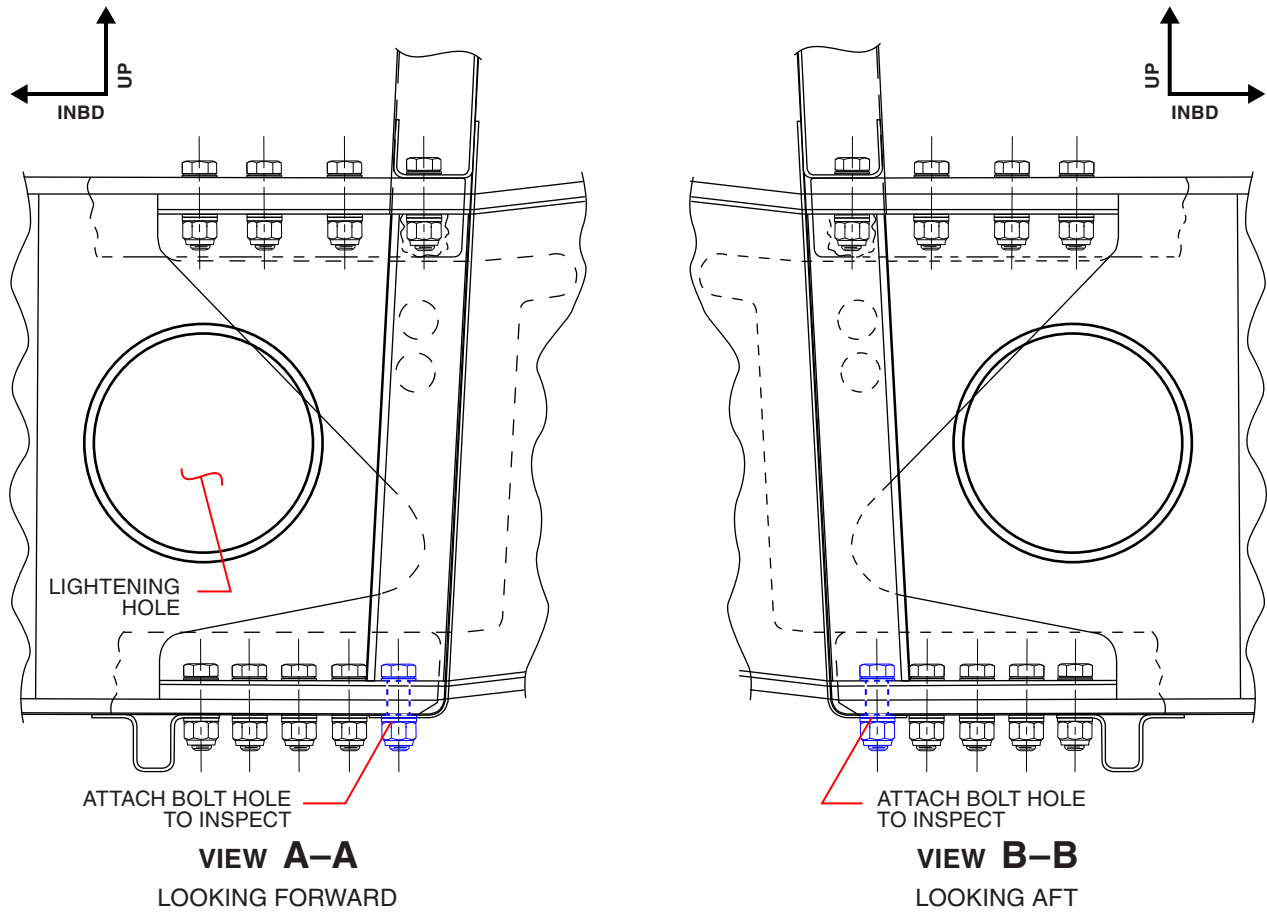

WARNING: Do not drive bolts into or out of the main spar attaching bolt holes (see Views A-A and B-B). Be careful to avoid damaging the bolt holes while removing and replacing the bolts. Refer to "Care for Bolts and Bolt Holes" in this service bulletin.

Figure 1, Sheet 1 of 2
Typical Main Wing Spar Attach Bolts and Spar Cross Section (Right Wing Shown)

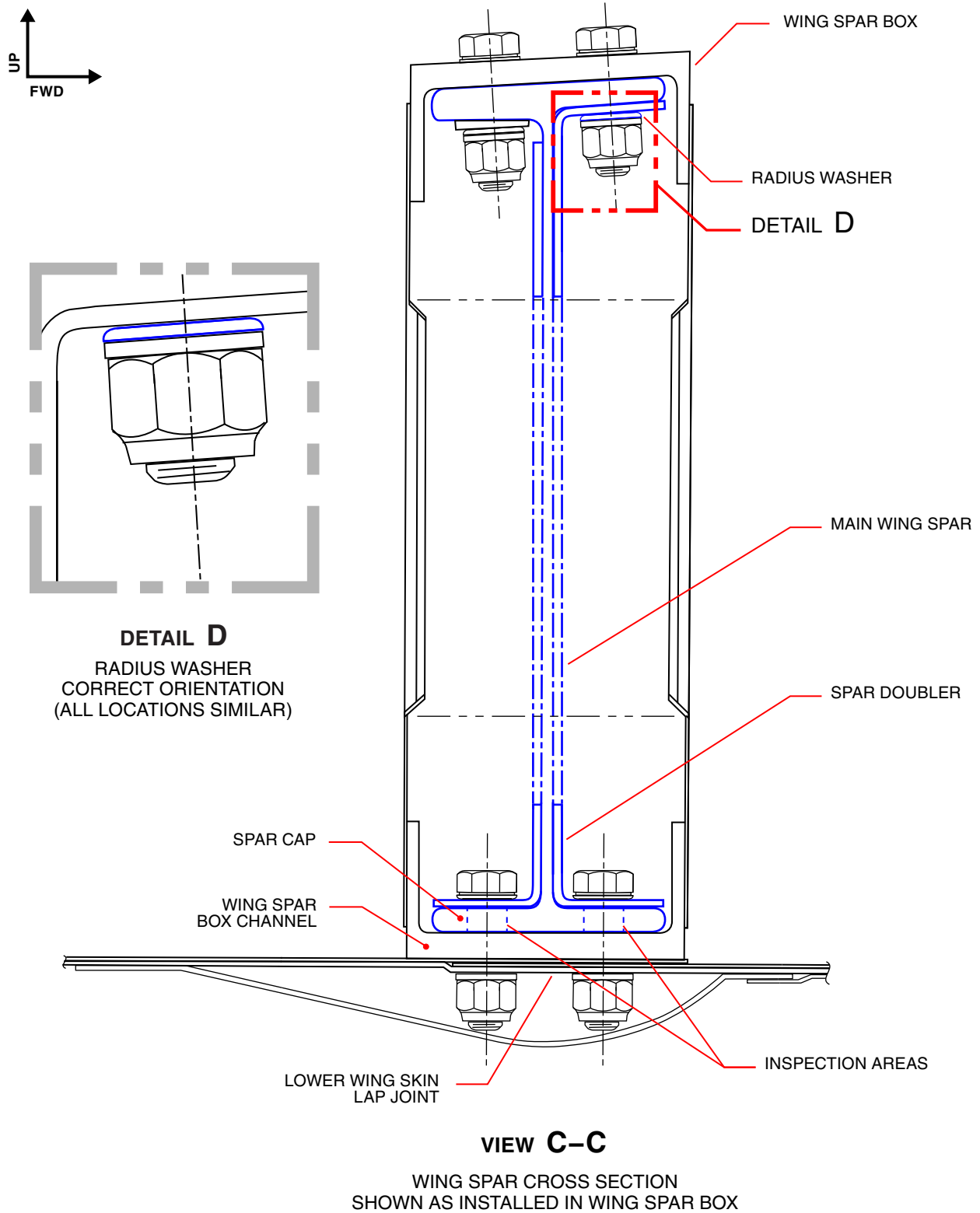

Figure 1, Sheet 2 of 2
Typical Main Wing Spar Attach Bolts and Spar Cross Section (Right Wing Shown)

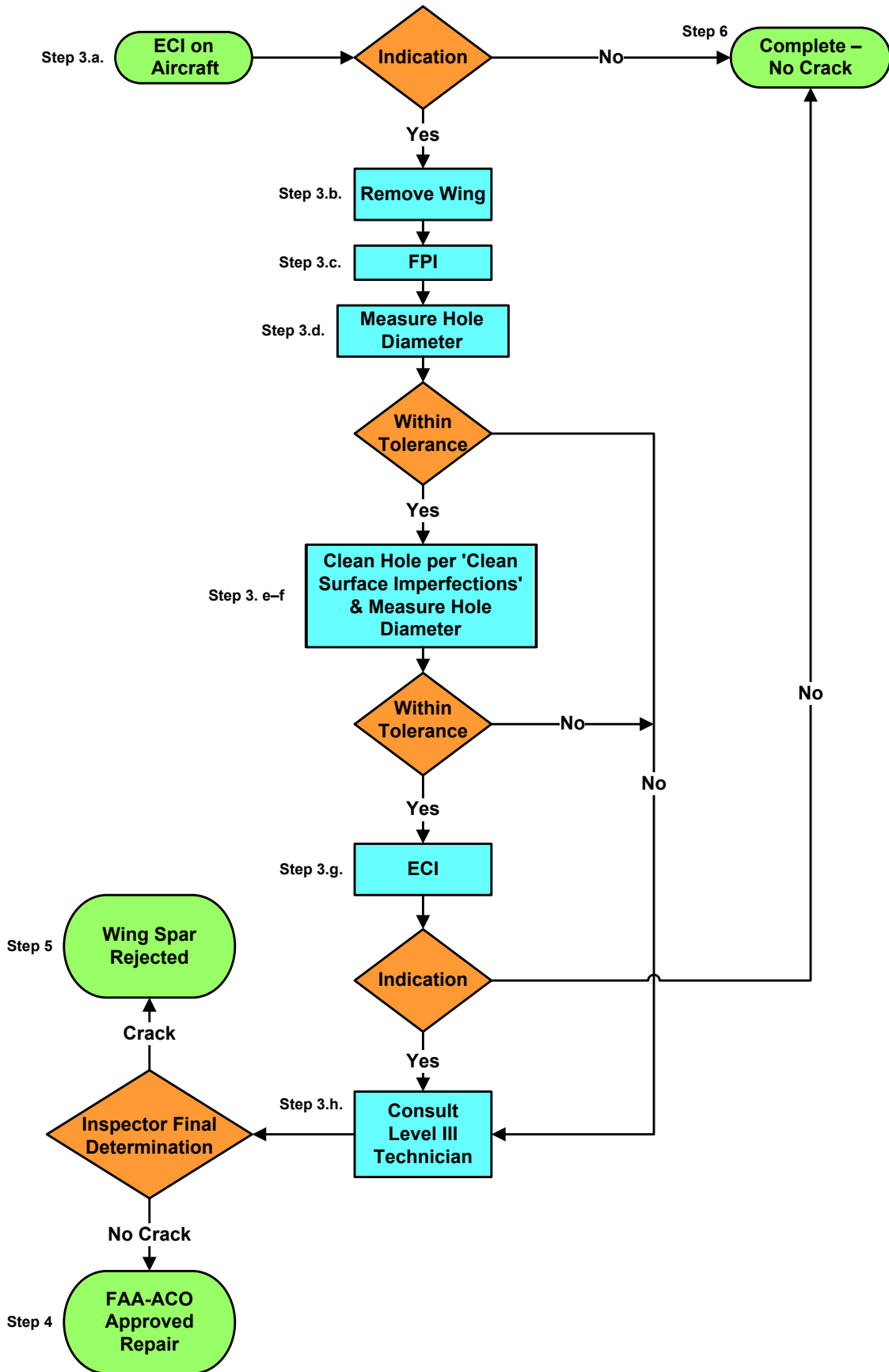

Figure 2
Inspection Process Flowchart

MATERIAL REQUIRED: On condition, quantity as required, wing spar attach bolts, nuts, washers, and other hardware, as provided in the applicable Piper IPC, per aircraft.

AVAILABILITY OF PARTS: Your Piper Approved Service Center

EFFECTIVITY DATE: This service bulletin is effective upon receipt.

SUMMARY: Please contact your Piper Approved Service Center to make arrangements for compliance with this service bulletin in accordance with the compliance time indicated.

NOTE: Please notify the factory of any address/ownership corrections. Changes should include aircraft model, serial number, and current owner's name and address.

Corrections and/or changes should be directed to:

PIPER AIRCRAFT, INC.

Attn: Customer Service

2926 Piper Drive

Vero Beach, FL 32960

or:

CustomerService@piper.com

Please include in subject line: "Aircraft ownership update"



U.S. Department
of Transportation
**Federal Aviation
Administration**

Aircraft Certification Service
Compliance & Airworthiness Division

Atlanta ACO Branch
1701 Columbia Ave.
College Park, Georgia 30337

September 22, 2021

In Reply, Reference FAA Correspondence #7A0-21-13428

Mr. Mitch Cannon
ODA Administrator
Piper Aircraft, Inc.
2926 Piper Drive
Vero Beach, FL 32960

Subject: Alternative Method of Compliance (AMOC) for Airworthiness Directive 2020-26-16, Paragraph (i) “Eddy Current Inspect” and (k) “Install New Bolts”.

Dear Mr. Cannon:

The Federal Aviation Administration (FAA) received your AMOC proposal dated September 17, 2021 proposing an AMOC to paragraphs (i) and (k) of Airworthiness Directive 2020-26-16.

The Atlanta ACO Branch approves your AMOC proposal to use Steps 1,2, and 3 as applicable, of Piper Service Bulletin 1345 revision A (SB 1345A) dated September 17, 2021 for compliance with paragraph (i) of Airworthiness Directive 2020-26-16. The Atlanta ACO Branch also approves your AMOC proposal to use SB 1345A step 6 for compliance with paragraph (k) of AD 2020-26-16. This AMOC applies to all airplane serial numbers listed in AD 2020-26-16, paragraph (c) “Applicability”.

The following material provides the data used to establish the acceptable level of safety which was the basis for approving the AMOC.

1. Piper Service Bulletin 1345 revision A, dated September 17, 2021.
2. Piper AMOC letter summarizing changes to SB 1345A.

This AMOC is transferable with the aircraft to a new owner/operator.

Before using this AMOC, notify your appropriate principal inspector, or lacking a principal inspector, the manager of the local flight standards district office/certificate holding district office.

The preceding paragraph also applies to any applicable foreign-registered aircraft upon transfer of the aircraft to the U.S. registry if compliance with the AMOC has not been accomplished. All provisions of AD 2020-26-16 that are not specifically referenced above remain fully applicable and must be complied with accordingly.

The Atlanta Aircraft Certification Office will revoke this AMOC if it is later determined that this AMOC does not provide an acceptable level of safety.

If you have any questions or need additional information, please contact Mr. William “Dan” McCully at telephone 404-474-5548, or electronic mail at william.mccully@faa.gov.

Sincerely,

 Digitally signed by
COREY A SPIEGEL
Date: 2021.09.22
16:16:25 -04'00'

(for)
Christina M. Underwood
Manager, Atlanta ACO Branch

Cc: 9-ASO-ORL-FSDO@faa.gov